

## ACE MOP Protocol Update: V3.0

Section	Summary of Changes
2.0	Added details for the site stored plasma.
4.2.2	Added site stored plasma aliquot in GREEN cap Sarstedt cryovials to Biofluid and Fecal Collection Schedule
5.1	Added green cap Sarstedt cryovials to kit supplies
5.3	Added instructions for green cap Sarstedt cryovials to filling of the tubes.
6.5	Added step for site to place pre-printed "SARSTEDT" Cryovial Label on the one (1) 2.0 ml cryovial with a green cap (ONLY applicable for 24M visit).
7.0	Added instructions for site to store GREEN cap Sarstedt cryovials
8.1.1	Updated instructions for 1 (D) for clarification
8.1.1	Updated picture of USPS shipping label with box; instruction number 7
8.1.2	Updated picture of cryobox
8.1.2	Updated instruction number 2 for site to NOT store GREEN cap Sarstedt cryovials with NCRAD shipped aliquots
Appendix B	Added section for site to record the last 4 digits of the GREEN cap Sarstedt cryovial barcode label
General	Updated formatting throughout document



**Arterial Stiffness, Cognition, and Equol Study**  
in collaboration with



**The National Centralized Repository for Alzheimer's Disease  
and Related Dementias (NCRAD)**

*Biofluid Collection, Processing and Shipment*

*Manual of Procedures*

*Version 3.0*

*Feb 2026*

## Table of Contents

Abbreviations.....	5
2.0 Purpose .....	6
3.0 NCRAD Information.....	7
3.1 NCRAD Contacts .....	7
3.2 NCRAD Hours of Operation .....	7
3.3 Holiday Schedules .....	8
3.4 NCRAD Holiday Observations .....	8
4.0 NCRAD Laboratory Collection.....	9
4.1 Site Required Equipment.....	9
4.2 Biospecimens Sent to NCRAD.....	9
4.2.1 <i>Biofluid Pre-intervention Collection Schedule</i> .....	9
4.2.2 <i>Biofluid and Fecal Collection Schedule</i> .....	10
4.2.3 <i>Biofluid Collection Summary Chart</i> .....	11
4.2.4 Biofluid Collection for Urine, Baseline, 12M, and 24M Visits.....	12
Specimen Collection Kits, Shipping Kits, and Supplies.....	14
5.1 Specimen Collection Kit Contents.....	14
5.2 Kit Supply to Study Sites .....	17
5.3 Filling Sarstedt Cryovials.....	17
6.0 Blood Collection and Processing Procedures.....	19
1.4 Labeling Samples.....	19
1.5 Pre-intervention Urine Collection Instructions.....	21
6.3 Fecal Collection with ME-200 & OMR-200 10 ml Tubes for Stool.....	25
Site personnel:.....	25
6.4 Whole Blood Collection with 10 ml Serum (Red-Top) Tube for Serum.....	28
6.5 Whole Blood Collection with EDTA (Purple-Top) Blood Collection Tube (10 ml) for Plasma and Buffy Coat (2 x 10ml) .....	31
7.0 Incomplete or Difficult Blood Draws .....	36
8.0 Packaging and Shipping Instructions .....	37
8.1 Ambient Packaging and Shipping Instructions.....	37
8.1.1 NCRAD Packaging Instructions—Stool Ambient Shipments.....	38

8.2	Frozen Packaging Information.....	41
8.2.1	Frozen Packaging Instructions .....	42
8.3	Frozen Shipping Instructions .....	47
9.0	Data Queries and Sample Reconciliation.....	49
10.0	Appendices List.....	50
	Appendix A: Rate of Centrifuge Worksheet.....	51
	Appendix B: Blood Sample and Shipment Notification Form.....	52
	Appendix C: Urine Sample and Shipment Notification Form .....	54
	Appendix D: Stool Sample and Shipment Notification Form .....	56

## Abbreviations

ACE	Arterial Stiffness, Cognition, and Equol Study
AD	Alzheimer's Disease
DNA	Deoxyribonucleic Acid
EDTA	Ethylene Diamine Tetra-acetic Acid
IATA	International Air Transport Association
IUGB	Indiana University Genetics Biobank
NCRAD	National Centralized Repository for Alzheimer's Disease and Related Dementias
RBC	Red Blood Cells
RCF	Relative Centrifugal Force
UPS	United Parcel Service
USPS	United States Postal Service
RPM	Revolutions Per Minute

## 2.0 Purpose

The collection of biofluids is an important part of the Arterial Stiffness, Cognition, and Equol (ACE) Study. The purpose of this manual is to provide study staff (PIs, study coordinators, phlebotomists) at the various study sites with instructions for collection and submission of biological samples for ACE study visits. It includes instructions for biofluid submission to NCRAD located in Indianapolis at Indiana University.

*The following samples will be sent to NCRAD:*

- Urine
- Serum
- Plasma
- Buffy Coat (DNA Extraction)
- Stool

*Additional samples collected but not shipped to NCRAD:*

- Plasma

This manual includes instructions for collection of urine, blood, and stool, fractionation of blood and urine from collection tubes, aliquoting, labeling, storage prior to shipping, and shipping to NCRAD. These procedures are relevant to all study personnel responsible for processing specimens being provided to NCRAD for the ACE protocol.

### 3.0 NCRAD Information

#### 3.1 NCRAD Contacts

**Tatiana Foroud, PhD, NCRAD Leader**

Phone: 317-274-2218

**Kelley Faber, MS, CCRC, Sr. Project Manager**

Phone: 317-274-7360

Email: [kelfaber@iu.edu](mailto:kelfaber@iu.edu)

**Michael Edler Jr. PhD, Laboratory Manager**

Phone: 317-278-9016

Email: [mcedler@iu.edu](mailto:mcedler@iu.edu)

**Diont'e Keys, BS, CCRP Study Coordinator**

Phone: 317-274-7546

Email: [dlkeys@iupui.edu](mailto:dlkeys@iupui.edu)

#### **General NCRAD Contact Information**

Phone: 1-800-526-2839

Alternate phone number: 317-278-8413

Email: [alzstudy@iu.edu](mailto:alzstudy@iu.edu)

Website: [www.ncrad.org](http://www.ncrad.org)

ACE Study Specific Webpage: <https://www.ncrad.org/coordinate-studies/ace>

#### **Sample Shipment Mailing Address**

ACE at NCRAD

Indiana University School of Medicine

351 West 10th Street

TK-217

Indianapolis, IN 46202

#### 3.2 NCRAD Hours of Operation

Indiana University business hours are from 8 AM to 5 PM Eastern Time, Monday through Friday.

Frozen samples must be shipped **Monday-Wednesday only**.

Check weather report to make sure impending weather events (blizzards, hurricanes, etc.) will not affect the shipping or delivery of the samples.

### 3.3 Holiday Schedules

- Please note that courier services may observe a different set of holidays.
- Please be sure to verify shipping dates with your courier prior to any holiday.

### 3.4 NCRAD Holiday Observations

Date	Holiday
January 1	New Year's Day
3 <sup>rd</sup> Monday in January	Martin Luther King, Jr Day
4 <sup>th</sup> Monday in May	Memorial Day
June 19	Juneteenth
July 4	Independence Day
1 <sup>st</sup> Monday in September	Labor Day
4 <sup>th</sup> Thursday in November	Thanksgiving
4 <sup>th</sup> Friday in November	Friday after Thanksgiving
December 25	Christmas Day
December 26-31	Winter Break

Please note that between December 24<sup>th</sup> and January 2<sup>nd</sup>, Indiana University will be open Monday through Friday for essential operations **ONLY** and will re-open for normal operations on January 2<sup>nd</sup>. If at all possible, biological specimens for submission to Indiana University should **NOT** be collected and shipped to Indiana University after the second week of December. Should it be necessary to ship blood samples for DNA extraction to Indiana University during this period, please contact the Indiana University staff before December 20th by e-mailing [alzstudy@iu.edu](mailto:alzstudy@iu.edu), so that they can arrange to have staff available to process incoming samples. **Please see: <https://ncrad.org/contact/holiday-closures> for additional information.**

- Please note that courier services may observe a different set of holidays.
- Please be sure to verify shipping dates with your courier prior to any holiday.
- **Weekend/holiday delivery must be arranged in advance with NCRAD staff.**

## 4.0 NCRAD Laboratory Collection

### 4.1 Site Required Equipment

The following materials and equipment are necessary for the processing of specimens at the collection site and are to be **supplied by the local site**:

- Personal Protective Equipment: lab coat, nitrile/latex gloves, safety glasses
- Tourniquet
- Alcohol Prep Pad
- Gauze Pad
- Bandage
- Butterfly needles and hub
- Microcentrifuge tube rack
- Sharps bin and lid
- Wet Ice Bucket
- Wet ice
- Dry ice

In order to process samples consistently across all projects and ensure the highest quality samples possible, project sites must have access to the following equipment:

- Centrifuge capable of  $\geq 2000 \times g$  with refrigeration to 4°C
- -80°C Freezer

In order to ship specimens, you must provide:

- Dry ice (approximately 45 lbs per shipment)

### 4.2 Biospecimens Sent to NCRAD

Samples are to be submitted according to the shipping methods outlined in [Section 8.0](#). Guidelines for the processing, storage location, and timing of sample collection are listed in the following tables

#### 4.2.1 Biofluid Pre-intervention Collection Schedule

Specimen Type	Pre-intervention
Urine	X

Urine will be collected in a sterile-screw-cap collection cup with integrated transfer device, transferred into a C & S Preservative Tube (Gray-Top) Urine

Collection Tube (4 ml), aliquoted, frozen at the study site and shipped to NCRAD.

#### 4.2.2 Biofluid and Fecal Collection Schedule

<u>Specimen Type</u>	<u>Baseline Visit</u>	<u>12 Month Visit</u>	<u>24 Month Visit</u>
Serum	X	X	X
Plasma	X	X	X*
Buffy Coat	X	X	X
Stool	X	X	X

\*For 24M visit **ONLY** site will store (1) 0.5 mL aliquot in a GREEN cap Sarstedt cryovial (2.0 mL)

Whole blood is collected in 2 types of tubes (10ml Serum Tube, 10ml purple-top EDTA tube). The 10ml red-top serum tube is processed locally into serum and then aliquoted, frozen at the study site and shipped to NCRAD. The 10ml EDTA tubes are processed locally into plasma and buffy coat fractions. They are then aliquoted, frozen at the study site, and shipped to NCRAD. 1 x 0.5mL plasma aliquot from the 24 Month Visit **ONLY** will be held at the site.

Stool will be collected in the ME-200 + OMR-200 stool collection containers and shipped ambient directly from the participant to NCRAD.

Consent forms must specify that any biological samples and de-identified clinical data may be shared with academic and/or industry collaborators through NCRAD. A copy of the consent form for each participant should be kept on file by the site investigator.

Ambient samples are to be submitted according to the shipping methods outlined in [Section 8.1](#). Frozen samples are to be submitted according to the shipping methods outlined in [Section 8.2](#). Guidelines for the processing, storage location, and timing of sample collection are listed in the following tables.

4.2.3 Biofluid Collection Summary Chart

Draw Tube Order	Collection Tube	Drawn At	Specimen Type	Aliquot Volume	Total Number of Aliquots	Shipping Temperature
1	URINE: C & S Preservative Tube (Gray-Top) Urine Collection Tube (4 ml)	Pre-intervention Visit	Urine	1.5 ml urine aliquots	3	Frozen
2	1 Serum Separator (Red-Top) Blood Collection Tube (10ml)	Baseline	Whole Blood	1.5 ml serum aliquots	Up to 4	Frozen
		12 Month				
		24 Month				
3	2 EDTA (Purple-Top) Blood Collection Tubes (10 ml)	Baseline	Whole blood	1.5 ml plasma aliquots *24M collection <b>only</b> (1) .5 ml plasma aliquot (GREEN cap Sarstedt cryovial)	Up to 8	Frozen *GREEN cap Sarstedt cryovial stored at site
		12 Month				
		*24 Month				
4	1 ME-200 + OMR-200 Bundle option	Baseline	Stool	N/A	N/A	Ambient
		12 Month				
		24 Month				

4.2.4 Biofluid Collection for Urine, Baseline, 12M, and 24M Visits

Sample Type	Tube Type	Study Visits Collecting Biospecimens	Number of Tube Supplied in Kit	Processing/Aliquoting	Typical # of tubes sent to NCRAD	Shipping Temperature
Urine for Urinalysis	URINE: C & S Preservative Tube (Gray-Top) Urine Collection Tube (4 ml)	Pre-intervention	3	3	3	Frozen
Whole Blood for isolation for serum	Serum Determination (Red-Top) Blood Collection Tube (10 ml)	Baseline	1	N/A	N/A	N/A
		12 Month				
		24 Month				
	Serum: 2.0 ml Sarstedt cryovial with red cap (residual volume placed in 2.0 ml Sarstedt cryovial with blue cap)	Baseline	4 (3 Red Cap, 1 Blue Cap Sarstedt cryovials)	1.5 ml serum aliquots per 2.0 ml Sarstedt cryovials	Up to 4	Frozen
		12 Month				
		24 Month				
Whole blood for isolation of plasma & buffy coat (for DNA extraction)	EDTA (Purple-Top) Blood Collection Tubes (10 ml)	Baseline	2	N/A	N/A	N/A
		12 Month				
		24 Month				
	PLASMA: 2.0 ml Sarstedt cryovials with purple cap (residual volume placed in 2.0 ml Sarstedt cryovials with blue cap)	Baseline	8 (6 Lavender Cap, 1 Blue Cap Sarstedt cryovials) **(1) GREEN cap Sarstedt	1.5 ml plasma aliquots per 2.0 ml Sarstedt cryovials *24M collection <b>only</b> (1) 0.5 ml plasma aliquot (GREEN cap Sarstedt)	Up to 8	Frozen
		12 Month				
		*24 Month				

			cryovials collected <b>only</b> at 24M			
	BUFFY COAT: 2.0 ml Sarstedt cryovial	Baseline	2 (1 Clear Cap Sarstedt cryovials)	1 ml buffy coat aliquot per 2.0 ml Sarstedt cryovial	2	
		12 Month				
		24 Month				
<b>Stool for microbiome analysis</b>	<b>1 ME-200 + OMR-200 Bundle option</b>	<b>Baseline</b>	<b>2</b>	<b>N/A</b>	<b>N/A</b>	<b>Ambient</b>
		<b>12 Month</b>	<b>2</b>			
		<b>24 Month</b>	<b>2</b>			

If a sample is not obtained at a particular visit, it should be recorded in the notes section of the **Blood Sample and Shipment Notification Form** (see [Appendix B](#)). Submit a copy to NCRAD with a reason provided for the omission and track it as a protocol deviation.

## Specimen Collection Kits, Shipping Kits, and Supplies

NCRAD will provide: 1) Urine, blood, and stool sample collection kits for research specimens to be stored at NCRAD, the Supplemental Supply Kit, the Frozen Shipment Supply Kit, and the Ambient Shipment Supply Kit; and 2) clinical lab supplies (with the exception of dry ice and equipment supplies listed in [Section 4.1](#)). The provided materials include blood tubes, pipettes, boxes for serum, plasma, and buffy coat aliquots, as well as shipping labels to send materials to NCRAD. Kit Number Labels, Patient ID Labels, and Collection Tube and Aliquot Labels will all be provided by NCRAD. Details regarding the blood kits are found in this Manual of Procedures. Collection Tube and Cryovial Labels will be pre-printed with study information specific to the type of sample being drawn. Ensure that all tubes are properly labeled during processing and at the time of shipment according to [Section 6.0](#).

### 5.1 Specimen Collection Kit Contents

Collection kits contain the following (for each participant) and provide the necessary supplies to collect samples from a given participant. Do not replace or supplement any of the tubes or kit components provided with your own supplies unless you have received approval from the NCRAD Study team to do so. *Please store all kits at room temperature until use.*

#### ACE Pre-intervention (Urine) Collection Kit

Quantity	ACE Pre-intervention (Urine) Kit Components
1	Sterile screw-cap urine collection cup with integrated transfer device
1	C&S preservative tube, 4ml
1	Disposable pipet (3ml)
3	Cryovial tube (2.0 ml) with yellow cap
5	Pre-printed Collection and Aliquot Tube Label
1	Patient ID Label
3	Kit Number Label
1	4 x 6 resealable bag

**ACE Stool and Blood-based Collection Kit- Baseline, Months 12/24**

Quantity	ACE Blood-Based Kit Components
2	EDTA tube, 10ml
1	Serum tube (red top), 10ml
6	Cryovial tube (2.0 ml) with purple cap
3	Cryovial tube (2.0 ml) with red cap
2	Cryovial tube (2.0 ml) with blue cap
2	Cryovial tube (2.0 ml) with clear cap
1	Cryovial tube (2.0 ml) with green cap
1	Centrifuge tube, 15 ml
18	Pre-printed Collection and Aliquot Tube Label
7	Patient ID Labels
3	Kit Number Labels
3	Disposable pipet (3ml)
1	Cardboard cryobox, 25 slot
1	ME-200 + OMR-200 Bundle option (stool kit)
1	Resealable bag

**ACE Urine Supplemental Supply Kit**

Quantity	ACE Pre-intervention (Urine) Kit Components
3	Sterile screw-cap urine collection cup with integrated transfer device
3	C&S preservative tube, 4ml
3	Disposable pipet (3ml)
9	Cryovial tube (2.0 ml) with yellow cap
3	Patient ID Label
3	4 x 6 resealable bag

**ACE Stool and Blood-Based Supplemental Supply Kit**

Quantity	Blood-Based Supplemental Supply Kit Components
6	EDTA tube, 10ml
3	Serum tube (red top), 10ml
18	Cryovial tube (2.0 ml) with purple cap
9	Cryovial tube (2.0 ml) with red cap
6	Cryovial tube (2.0 ml) with blue cap
6	Cryovial tube (2.0 ml) with clear cap
4	Cryovial tube (2.0 ml) with green cap
3	Centrifuge tube, 15 ml
9	Disposable pipet (3ml)
3	Cardboard cryobox, 25 slot
3	ME-200 + OMR-200 Bundle option
1	Large resealable bag
12	PTID labels
3	4 x 6 resealable bag

**ACE Frozen Blood/Urine Shipping Supply Kit**

Quantity	Frozen Shipping Kit Components
1	Dry Ice UPS label
1	UN3373 sticker
1	Fragile labels
1	Waybill
1	Med Frozen shipper/Lg brain box
8	Biohazard bag w/ absorbent sheet

**ACE Ambient Stool Shipping Supply Kit**

Quantity	Frozen Shipping Kit Components
1	Plastic biohazard bag with absorbent sheet
1	Small IATA shipping box with insulated cooler (cool pack)
1	UN3373 Biological Substance Category B label
1	List of contents card
1	USPS Shipping Label

**Individual Supplies**

Quantities	Items Available upon request within the NCRAD kit module
By Request	Serum red top tube (10 ml)
By Request	EDTA (Purple-Top) Blood Collection Tube (10 ml)
By Request	Sterile screw-cap urine collection cup with integrated transfer device

By Request	C&S preservative tube, 4ml
By Request	ME-200 + OMR-200 Bundle option
By Request	Disposable graduated transfer pipette (3ml)
By Request	Centrifuge tube, 15 ml
By Request	Labels for handwritten ACE ID
By Request	Resealable bag
By Request	Cardboard cryobox, 25 slot
By Request	Plastic Biohazard bag with absorbent sheet
By Request	UN3373 sticker
By Request	Dry Ice label
By Request	Fragile labels
By Request	Shipping box
By Request	Cryovial tube (2.0 ml) with purple cap
By Request	Cryovial tube (2.0 ml) with red cap
By Request	Cryovial tube (2.0 ml) with blue cap
By Request	Cryovial tube (2.0 ml) with clear cap
By Request	Cryovial tube (2.0 ml) with yellow cap
By Request	Cryovial tube (2.0 ml) with green cap
By Request	DNA Genotek Stool Collection Paper

## 5.2 Kit Supply to Study Sites

Each site will be responsible for ordering and maintaining a steady supply of kits from NCRAD. We advise sites to keep a supply of each kit type available. Be sure to check your supplies and order additional materials before you run out or supplies expire so you are prepared for study visits. Please go to [www.kits.iu.edu/ACE](http://www.kits.iu.edu/ACE) to request additional kits and follow the prompts to request the desired supplies. Options include ordering a specific number of kits; we are also including the option of simply ordering the desired amount of extra supplies.

Please allow **TWO-THREE weeks** for kit orders to be processed and delivered.

## 5.3 Filling Sarstedt Cryovials

In order to ensure that NCRAD and University of Pittsburgh receives a sufficient amount of sample for processing and storage, and to avoid cracking of the tubes prior to shipment, each aliquot tube should be filled to the assigned volume after processing is completed (refer to detailed processing instructions for average yield per sample). Over-filled tubes may burst once placed in the freezer, resulting in a loss of sample.

Aliquot the remaining biologic material as the residual volume and ship to NCRAD. Ship *all* material to NCRAD, except one 0.5mL green capped cryovial

from the 24M visit. Fill one cryovial with 0.5ml and set aside. After that, the remainder of the aliquots will be in 1.5mL volume until the residual. For example, if 3.7 ml of a plasma sample is obtained, fill 1 cryovial with 0.5ml, then 2 with 1.5 mL, and one additional cryovial with the remaining 0.2 mL.

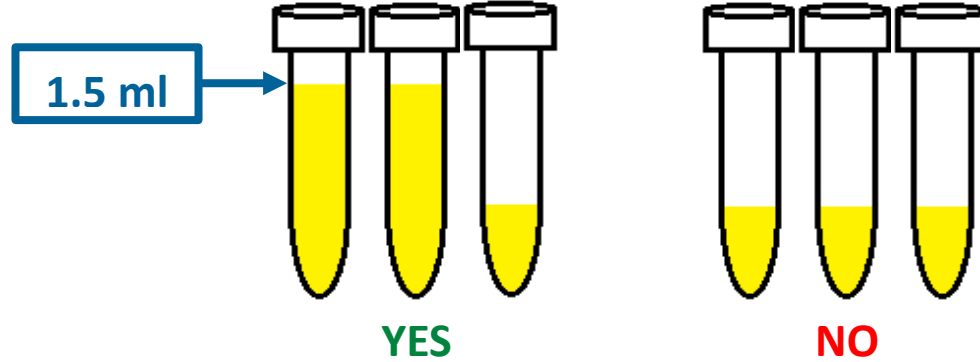

**Please note:** It is critical for the integrity of future studies using these samples that study staff note if an aliquot tube contains a residual volume (anything under 1.5 ml). Please highlight that the aliquot contains a small volume by utilizing the blue cryovial cap provided in each kit. Please record the last four digits of the residual aliquot on the Biological Sample and Notification Form. **If there are any unused cryovials, please do not send the empty cryovials to NCRAD. These unused cryovials (ensure labels are removed) can be saved as part of a supplemental supply at your site or the cryovials can be disposed of per your site’s requirements.**

To assist in the preparation and aliquoting of samples, colored caps are used for the aliquot tubes. The following chart summarizes the association between cap color and type of aliquot.

Cap Color	Sample Type
Purple	Plasma
Clear	Buffy Coat
Red	Serum
Yellow	Urine
Blue	Residual Aliquot (Plasma or Serum)
Green	0.5mL Plasma Aliquot (Site stored Plasma for University of Pittsburgh from 24M visit ONLY)

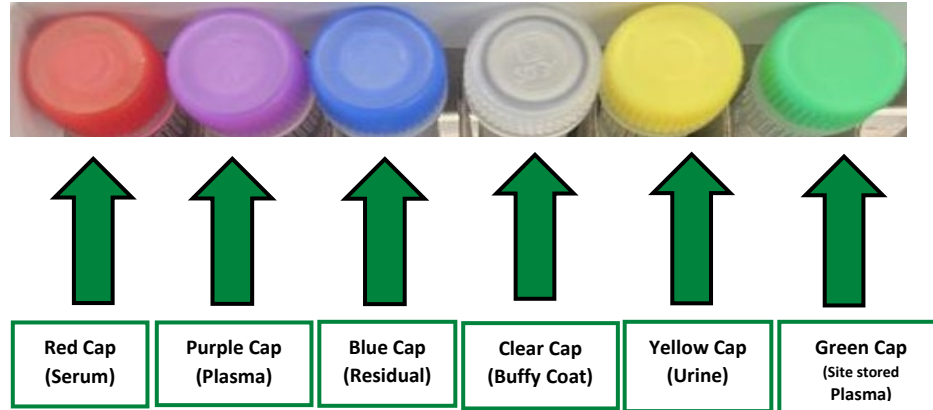

## 6.0 Blood Collection and Processing Procedures

### 1.4 Labeling Samples

In order to ensure the highest quality samples are collected, it is essential to follow the specific collection and shipment procedures detailed in the following pages. Please read the following instructions first before collecting any specimens. Have all your supplies and equipment out and prepared prior to drawing blood.

#### 1.4.2 Label Type Summary

1. Kit Number Label
2. HEAD ID Label
3. Collection Tube and Aliquot Label



The **Kit Number Labels** do not indicate a specimen type but are affixed on the Biological Sample and Shipment Notification Form and on specific packing materials. This label ties together all specimens collected from one participant at one visit.

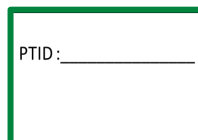

The **ACE Patient ID Labels** are placed on all collection tubes. This label is used to document the individual's unique Participant ID.



The **Collection Tube and Aliquot Labels** for blood derivatives are placed on all collection and aliquot tubes.

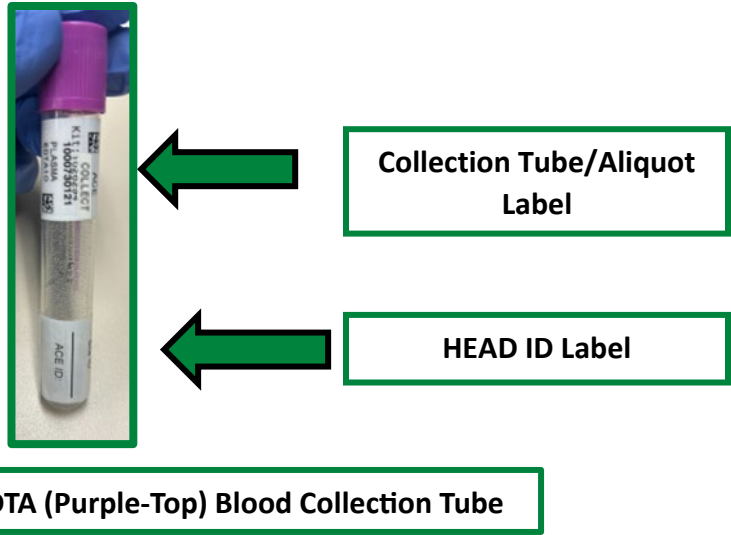

Each collection tube will contain two labels: the collection tube label and the HEAD ID Label. Be sure to place labels in the same configuration consistently among tubes, with the barcoded label near the top of the tube and the handwritten ACE ID label near the bottom of the tube.

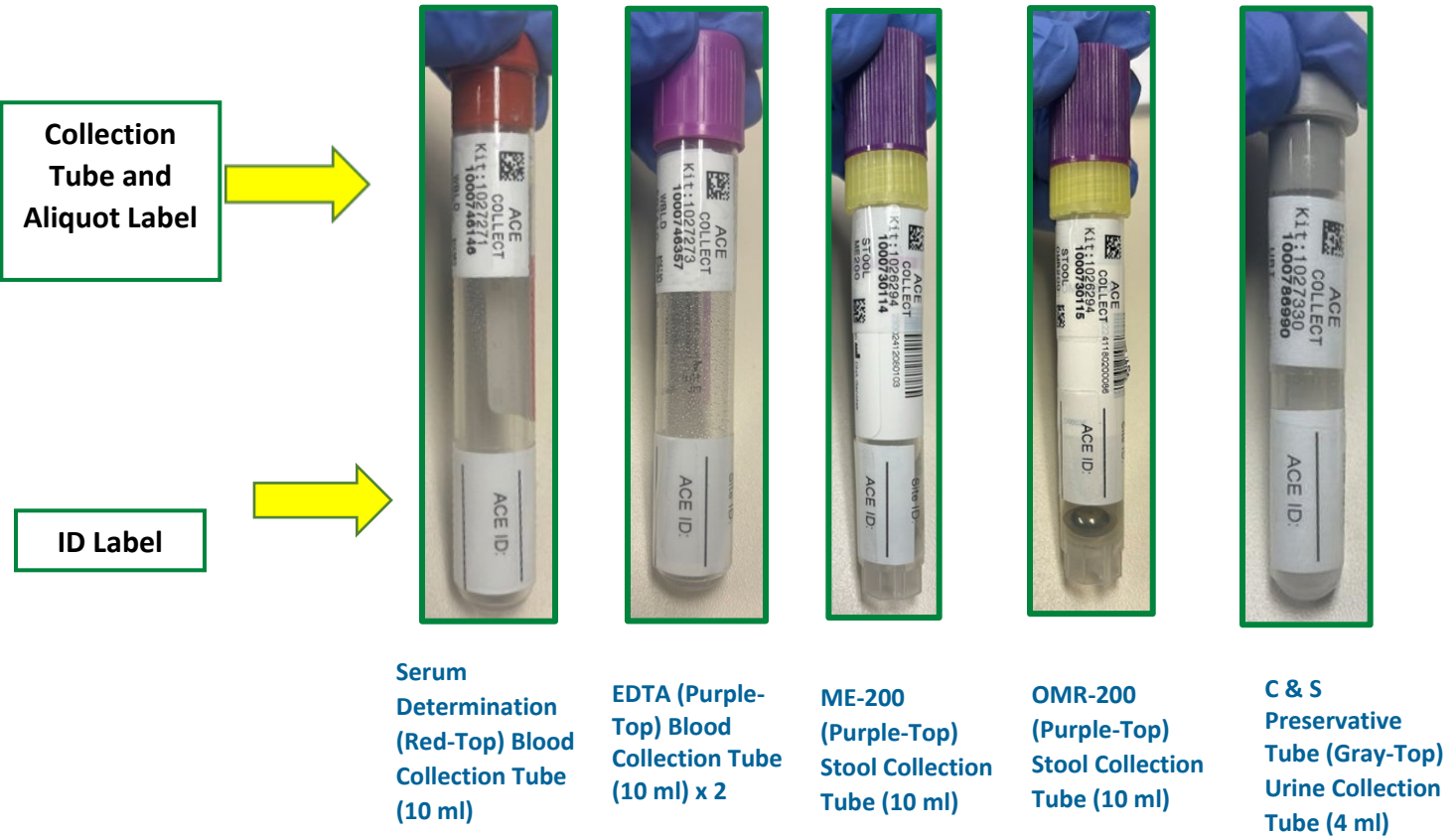

In order to ensure the label adheres properly and remains on the tube, please follow these instructions:

- Place Collection Tube and Aliquot Labels on **ALL** collection tubes and cryovials **BEFORE** sample collection. This should help to ensure the label properly adheres to the tube before exposure to moisture or different temperatures.
- Using a fine point permanent marker, fill-in and place the HEAD ID Labels on the EDTA (purple-top) tubes **BEFORE** sample collection. These labels are placed on collection tubes in addition to the Collection Tube Label.
- The Collection Tube Labels contain a 2D barcode on the left-hand and bottom right-hand side of the label.
- Place label **horizontally** on the tube (wrapped around sideways if the tube is upright) with barcode toward the tube cap.

Take a moment to ensure the label is **completely adhered** to each tube. It may be helpful to roll the tube between your fingers after applying the label. The following pictures show the correct orientation of the labels on the collection tubes and cryovials.

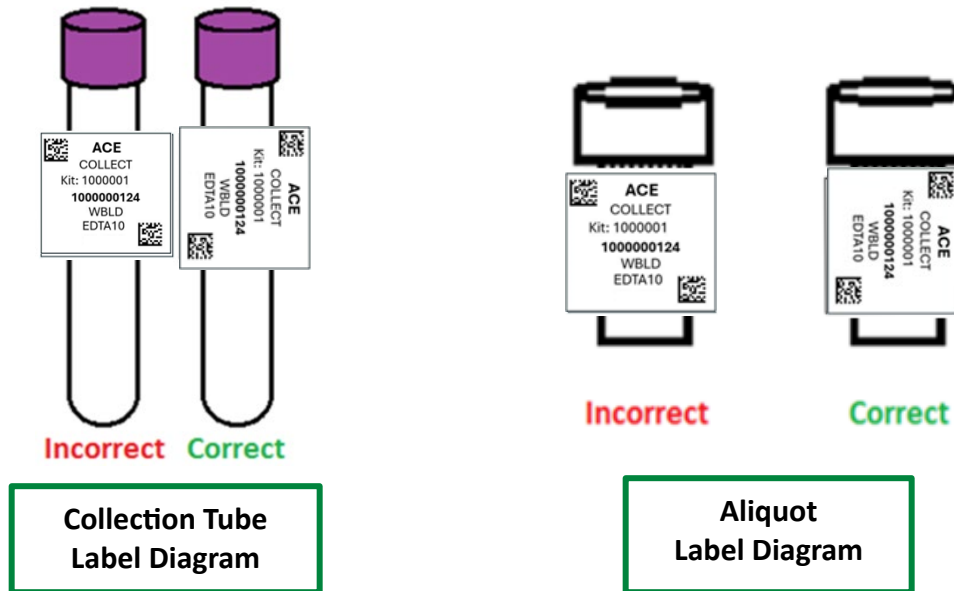

### 1.5 Pre-intervention Urine Collection Instructions

See [training video](#) for urine collection.

1. Place completed ACE Patient ID Label and Collection and Aliquot **“URINE”** Tube Label on the **C&S Preservative Tube** (gray top tube). Place pre-printed

Aliquot “Urine” Tube Labels on the (3) 2.0 ml cryovial tubes with yellow caps.

2. Give urine cup to patient and instruct on how to collect a clean, midstream urine sample:

### **1.5.2 Midstream Clean-Catch Collection Instructions for Participants**

#### **Preparation:**

- a. Verify you have been provided soap towelettes and a urine collection cup.
- b. Do not touch the inside of the cup.
- c. Remove the cap and place the cup on the counter with the straw facing upwards.
- d. Do not touch the inside of the cap or straw.
- e. Do not remove the yellow label on the top of the cup.
- f. Wash hands thoroughly with soap and water.

#### **Male Instructions:**

- a. Cleanse the end of the penis with a soap towelette beginning at the urethral opening and work away from it (for uncircumcised males, the foreskin must first be retracted).
- b. Void the first portion of the urine into the toilet.
- c. While continuing to void, place the collection cup into the midstream to collect the urine specimen. Do not touch the inside or lip of the cup with the hands or any other part of the body. Void remained of urine into toilet.
- d. Replace the cap on the cup touching only the outside surfaces of the cap and cup.
- e. Screw the lid tightly.

#### **Female Instructions:**

- a. Standing in a squatting position over the toilet, separate the folds of skin around the urinary opening. Cleanse the area around the opening with the first towelette. Repeat using the second towelette.
- b. Void the first portion of the urine into the toilet.
- c. While continuing to void, place the collection cup into the midstream to collect the urine specimen. Do not touch the

- inside or lip of the cup with the hands or any other part of the body. Void remainder of urine into the toilet.
- d. Replace the cap on the cup touching only the outside surfaces of the cup.
  - e. Screw the lid on tightly.
3. Apply clean gloves and receive urine sample as soon as possible after collection. Place sample on a clean paper towel.
  4. Peel back protective sticker on top of the urine cup to expose rubber covered cannula.
  5. Push the **C&S Preservative Tube** (gray top tube) firmly down into the integrated transfer port so that the needle will pierce the stopper on the C&S Preservative Tube. Negative pressure will allow urine to flow into the tube.
    - a. Hold tube in position until flow stops.
    - b. Remove tube.
    - c. Invert the tube 8-10 times.
  6. Once the tube has mixed successfully with the preservative. Remove the gray rubber-tube stopper and using a 3ml pipette, dispense 1.5ml of urine into each yellow-top cryovial.
  7. Remove the urine by tilting the tube and placing the pipette tip along the lower side of the wall. Using a disposable pipette, transfer urine into the pre-labeled cryovials with the yellow caps. Aliquot 1.5 ml per cryovial (total vials = up to three with 1.5 mL). Be sure to only place urine in cryovials labeled with the "URINE" label and yellow caps.
  8. Place the labeled cryovials in a cryobox and place on dry ice. Transfer to -80°C Freezer when possible. Store all samples at -80°C until shipped to NCRAD on dry ice. Record time aliquots placed in freezer and storage temperature of the Freezer on the Urine Sample and Shipment Notification Form ([Appendix C](#)).
  9. Record date and time of urine sample collection and storage temperature of freezer on the Urine Sample and Shipment Notification Form ([Appendix C](#)). Include this sample form with the shipment to NCRAD.

# Pre-intervention Urine Collection Instructions

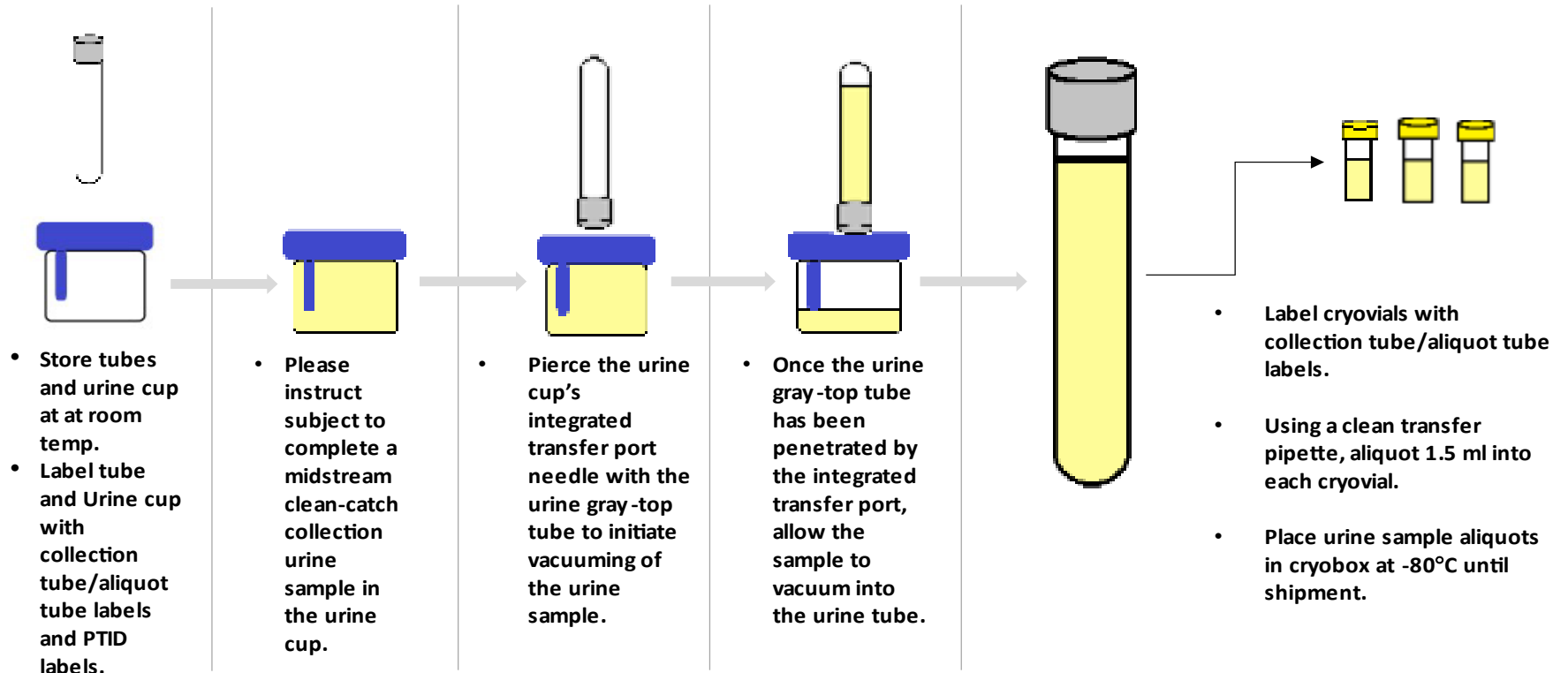

### 6.3 Fecal Collection with ME-200 & OMR-200 10 ml Tubes for Stool

**Site personnel:**

- Please label the stool tubes in reference to section 6.1.
- Please advise the following instructions to the participant and provide a printout of the instructions found on the NCRAD ACE Study website. Instructions will also be provided to the participant in the stool kit:

1. Empty your bladder before beginning the collection. Collect fecal sample free of urine and toilet water. Toilet paper or tissues may be required.
2. While holding the yellow tube top, unscrew ONLY the purple cap from the kit and set aside for later use.

**\*IMPORTANT:**

- Do NOT remove the yellow tube top.
- Do NOT spill the stabilizing liquid in the tube.

3. Using a spatula, collect a small amount of fecal sample.



4. Transfer the fecal sample into the yellow tube top. Repeat until the sample fills the yellow tube top.

**\*IMPORTANT:**

- Do NOT push sample into the tube.

5. Scrape horizontally across the tube top to level the sample and remove any excess. Wipe exterior of tube and top with toilet paper or tissue as needed.
6. Pick up the purple cap with the solid end facing down and screw onto the yellow tube top until tightly closed.



7. Shake the sealed tube as hard and fast as possible in a back-and-forth motion for a minimum of 30 seconds.

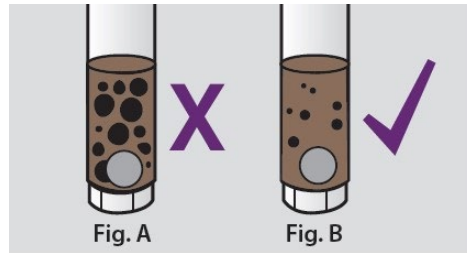

**\*\*Please advise and emphasize to the participant that the stool sample contents should reflect Figure B. If the sample arrives not reflecting Figure B then we will notify the site to recollect.**

8. The fecal sample will be mixed with the stabilizing liquid in the tube; not all particles will dissolve.
  9. Place spatula in original packaging or wrap in toilet paper and discard in garbage.
  10. Once the samples have been collected, please instruct the participant to place the samples in a biohazard bag and seal it.
  11. Instruct the participant to record the **date and time** of collection on the Stool Sample Form.
  12. Advise the participant to properly place samples in the biohazard bag into the provided shipping box along with the Stool Sample Form on top of the samples. Samples may be kept ambient, and do not need to be refrigerated or frozen.
- \*\*Site personnel will need to pre-apply the UN3373 Biological Substance Category B label, the USPS Express Shipping Label and the USPS postage sticker on the shipping box provided to the participant and complete the first portion of Stool Sample Form.**
13. Finally, please instruct the participant to place the package out for a USPS pickup – whether that be in a mailbox, or a local USPS pickup location.

## At-Home Stool Collection Instructions



- Empty your bladder before beginning the collection. Collect fecal sample free of urine and toilet water. Toilet paper or tissues may be required.



- While holding the yellow tube top, unscrew ONLY the purple cap from the kit and set aside for later use.



- Do NOT remove the yellow tube top.
- Do NOT spill the stabilizing liquid in the tube.



- Use the spatula to collect a small amount of fecal sample.



- Transfer the fecal sample into the yellow tube top. Repeat until the sample fills the yellow tube top



- Scrape horizontally across the tube top to level the sample and remove any excess. Wipe exterior of tube and top with toilet paper or tissue as needed.



- Pick up the purple cap with the solid end facing down and screw onto the yellow tube top until tightly closed.



- Shake the sealed tube as hard and fast as possible in a back-and-forth motion for a minimum of 30 seconds.

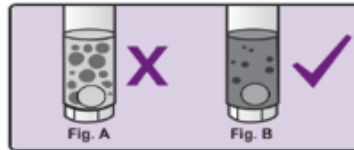

- The fecal sample will be mixed with the stabilizing liquid in the tube; not all particles will dissolve.

**\*IMPORTANT:**

- Continue shaking if large particles remain as shown in the above figure.



- Subject will put samples in the provided biohazard bag and in the shipping box.
- UPS shipping label and IATA regulated labels will need to be applied to the shipping pack and shipping box.
- Instruct subject to store at room temperature and transport shipment to the nearest UPS location for shipment.



- Place spatula in original packaging or wrap in toilet paper and discard in garbage.

#### 6.4 Whole Blood Collection with 10 ml Serum (Red-Top) Tube for Serum

1. Set centrifuge 4°C to pre-chill before use.
2. Place completed ACE Patient ID Label and Collection “**SERUM**” Tube Labels on the Plain Red-Top Serum Blood Collection Tube. Place pre-printed Aliquot “**SERUM**” Tube Labels on the three (3) 2.0 ml cryovial tubes with red caps and one (1) 2.0 ml cryovial with blue cap (if necessary, for residual).
3. Using a blood collection set and a holder, collect blood into **Plain Red-Top Serum Blood Collection Tubes (10 ml)** using your institution's recommended procedure for standard venipuncture technique.

The following techniques shall be used to prevent possible backflow:

- a. Place donor's arm in a downward position.
  - b. Hold tube in a vertical position, below the donor's arm during blood collection.
  - c. Release tourniquet as soon as blood starts to flow into tube.
  - d. Make sure tube additives do not touch the stopper or the end of the needle during venipuncture.
4. Allow at least 10 seconds for a complete blood draw to take place in each tube. **Ensure that the blood has stopped flowing into each tube before removing the tube from the holder.** The tube with its vacuum is designed to draw 5 ml of blood into the tube.
    - a. If complications arise during the blood draw, please note the difficulties on the ‘Biological Sample and Shipment Notification Form’. Do not attempt to draw an additional Serum tube at this time. Process blood obtained in existing Serum tube.
  5. **CRITICAL STEP:** Immediately after blood collection, **gently** invert/mix (180 degree turns) each tube 5 times.
  6. **CRITICAL STEP:** Allow blood to clot at room temperature by placing it upright in a vertical position in a tube rack for 30 minutes. If after 30 minutes the sample is not clotted, allow it to set up to 60 minutes to clot. Serum samples need to be spun, aliquoted, and placed in the freezer within 2 hours from the time of collection.

7. After clotting, centrifuge the collection tube for 10 minutes at 2000 x g at 4°C. **It is critical that the tube be centrifuged at the appropriate speed to ensure proper serum separation** (see worksheet in [Appendix A](#) to calculate RPM)
  - a. Equivalent rpm for spin at 2000 x g
  - b. While centrifuging, remember to record all times, temperatures and spin rates on the Biological Sample and Shipment Notification Form [Appendix B](#).
  - c. Serum samples need to be spun, aliquoted, and placed in the freezer within 2 hours from the time of collection.
  - d. Record time aliquoted on the Biological Sample Shipment and Notification Form.
  
8. Remove the serum by tilting the tube and placing the pipette tip along the lower side of the wall. Using a disposable pipette, transfer serum into the pre-labeled cryovials with the red caps. Aliquot 1.5 ml per cryovial (total vials = up to three with 1.5 mL and one residual with <1.5 ml). Be sure to only place **serum** in cryovials labeled with the “SERUM” label and red caps. If there is extra serum left, use 1 extra blue-cap cryovial provided for another <1.5 ml aliquot of serum and label as appropriate. **If a residual aliquot is created, document the sample number and volume on the Blood Sample and Shipment Notification Form.**
  
9. Place the labeled cryovials in a cryobox and place on dry ice. Transfer to **-80°C Freezer when possible**. Store all samples at **-80°C until shipped** to NCRAD on dry ice. Record time aliquots placed in freezer and storage temperature of the Freezer on the Biological Shipment Notification form.



## Serum Preparation (10ml Red Top Tube)



Step One

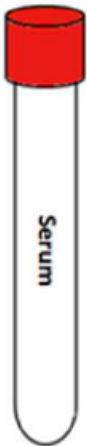

- Inspect tube expiration date and confirm tube is not expired.
- Store tubes at room temperature.
- Label tubes and cryovials with pre-printed subject labels prior to blood draw.

Step Two

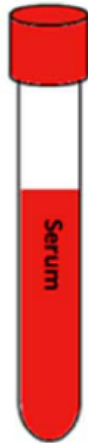

- Collect blood in Serum Tube allowing blood to flow for 10 seconds and ensuring blood flow has stopped.

Step Three

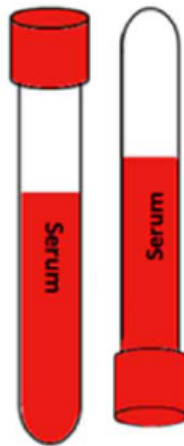

- Immediately after blood draw, invert tube 5 times to mix samples.

Step Four



- Allow blood to clot for 30 minutes.
- Within 60 minutes of blood draw, centrifuge samples at 2000 x g for 10 minutes at 4°C.

Step Five



- Must be spun, aliquoted, and stored in -80°C freezer within 2 hours of collection.

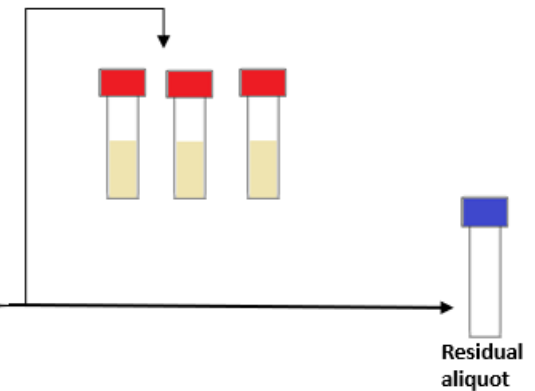

- Adhere preprinted labels to the red-cap cryovials.
- Aliquot 1.5 ml into each cryovial tube.
- If a residual aliquot is created, document specimen number and volume on Sample Notification Form.
- Store plasma aliquots at -80°C until shipment.

## 6.5 Whole Blood Collection with EDTA (Purple-Top) Blood Collection Tube (10 ml) for Plasma and Buffy Coat (2 x 10ml)

1. Set centrifuge to 4°C to pre-chill before use.
2. Place completed ACE Patient ID Label and pre-printed “**PLASMA**” Collection Tube and Aliquot Label on the purple-top EDTA tubes. Place pre-printed “**PLASMA**” Cryovial Labels on the six (6) 2.0 ml cryovials with purple caps and one (1) 2.0 ml cryovial with blue cap (if necessary, for residual). Place pre-printed “**BUFFY COAT**” Cryovial Label on the two (2) 2.0 ml cryovials with clear caps. Place pre-printed “**SARSTEDT**” Cryovial Label on the (1) 2.0 ml cryovial with a green cap (ONLY applicable for 24M visit).
3. Using a blood collection set and a holder, collect blood into the **EDTA (Purple-Top) Blood Collection Tubes (10 ml)** using your institution's recommended procedure for standard venipuncture technique.

**The following techniques shall be used to prevent possible backflow:**

- a. Place participant's arm in a downward position.
  - b. Hold tube in a vertical position, below the participant's arm during blood collection.
  - c. Release tourniquet as soon as blood starts to flow into tube.
  - d. Make sure tube additives do not touch stopper or end of the needle during venipuncture.
4. Allow at least 10 seconds for a complete blood draw to take place in each tube. **Ensure that the blood has stopped flowing into the tube before removing the tube from the holder.** The tube with its vacuum is designed to draw 10 ml of blood into the tube.

If complications arise during the blood draw, please note the difficulties on the ‘Blood Sample and Shipment Notification Form’. Do not attempt to draw an additional EDTA tube at this time. Process blood obtained in existing EDTA tube.

5. **CRITICAL STEP: Immediately after blood collection, gently invert/mix (180 degree turns) the EDTA tubes 8-10 times.**
6. **CRITICAL STEP: Immediately after inverting the EDTA tubes, place them on wet ice until centrifugation begins.**

7. Centrifuge balanced tubes for 10 minutes at 2000 x g and 4°C. **It is critical that the tubes be centrifuged at the appropriate speed and temperature to ensure proper plasma separation (see worksheet in [Appendix A](#) to calculate RPM.)**
  - a. Equivalent rpm for spin at 2000 x g
  - b. While centrifuging, remember to record all times, temperatures and spin rates on the Biological Sample and Shipment Notification Form.
  - c. Record original volume drawn for each tube in spaces provided on the Biological Sample Shipment and Notification Form.
  - d. Plasma samples need to be spun, aliquoted, and placed in the freezer within 2 hours from the time of collection.
  - e. Record time aliquoted on the Biological Sample Shipment and Notification Form.
  
8. Remove the plasma, being careful not to agitate the packed red blood cells at the bottom of the tube. Tilt the tube and place a disposable pipette tip along the lower side of the wall without touching the pellet (buffy coat) so that plasma is not contaminated (see below). Transfer plasma from both EDTA tubes into the 15 ml conical tube and gently invert 3 times.
  
9. Aliquot 1.5 ml per cryovial (total vials = up to 7 with 1.5 ml each). At the 24M visit, first aliquot 0.5ml plasma into the green capped cryovial and set it aside. Then aliquot 1.5 ml per cryovial. Each EDTA tube should yield, on average, 4-5 ml of plasma. Be sure to only place **plasma** in cryovials with purple caps and labeled with “PLASMA” labels. Take caution not to disturb the red blood cells at the bottom of the tube. If there is extra plasma left, use 1 blue-capped cryovial with “PLASMA” label for another <1.5 ml aliquot of plasma. **If a residual aliquot (<1.5 ml) is created, document the sample number and volume on the Blood Sample and Shipment Notification Form ([Appendix B](#)).**

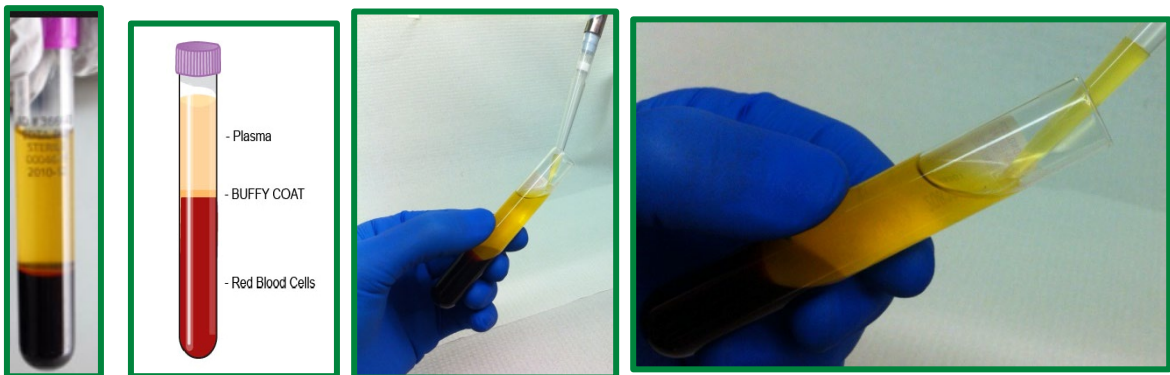

**NOTE: When pipetting plasma from the plasma tube into the cryovials, be very careful to pipette the plasma top layer only, leaving the buffy coat and the red blood cell layers untouched.**

- 10. Place the labeled cryovials in a cryobox and place on dry ice. Transfer to **-80°C Freezer when possible**. Store all samples at **-80°C until shipped** to NCRAD on dry ice. Record time aliquots placed in freezer and storage temperature of the freezer on Blood Sample Shipment and Notification Form.
- 11. After plasma has been removed from the EDTA (Purple-Top) Blood Collection Tubes (10 ml), aliquot buffy coat layer (in the top layer of cells, the buffy coat is mixed with RBCs – see following figure) into labeled cryovials with clear caps using a pipette. **Aliquot each buffy coat into a separate cryovial**. The buffy coat aliquot is expected to have a reddish color from the RBCs. Be sure to place buffy coat into cryovials with the clear caps and “BUFFY COAT” label.

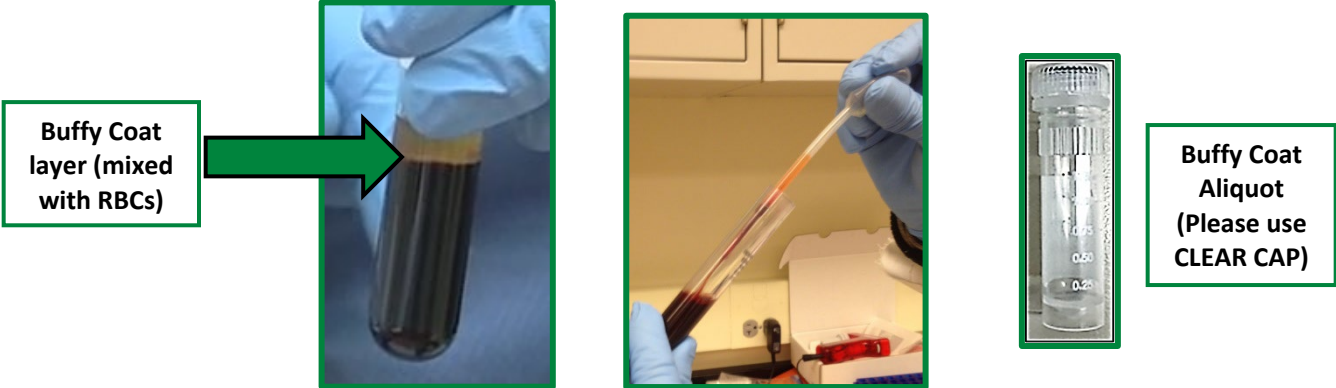

- 12. Dispose of tube with red blood cell pellet according to your site’s guidelines for disposing of biomedical waste.
- 13. Place the labeled cryovials in the 25-slot cryovial box and place on dry ice. Transfer to **-80°C Freezer when possible**. Store all samples at **-80°C until shipped** to NCRAD on dry ice.
- 14. Place the labeled green-cap cryovial in a **-80 °C** freezer, separate from cryovials designated for shipment to NCRAD.

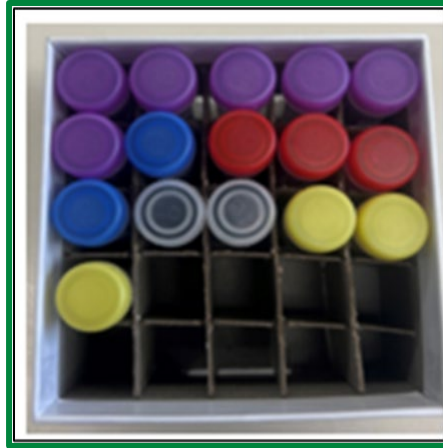

**Plasma (up to 7 possible), Buffy Coat (2), Serum (up to 4 possible) and Urine (3) Aliquots**

## Plasma and Buffy Coat Preparation EDTA Purple-Top Tube (2 x 10 ml)

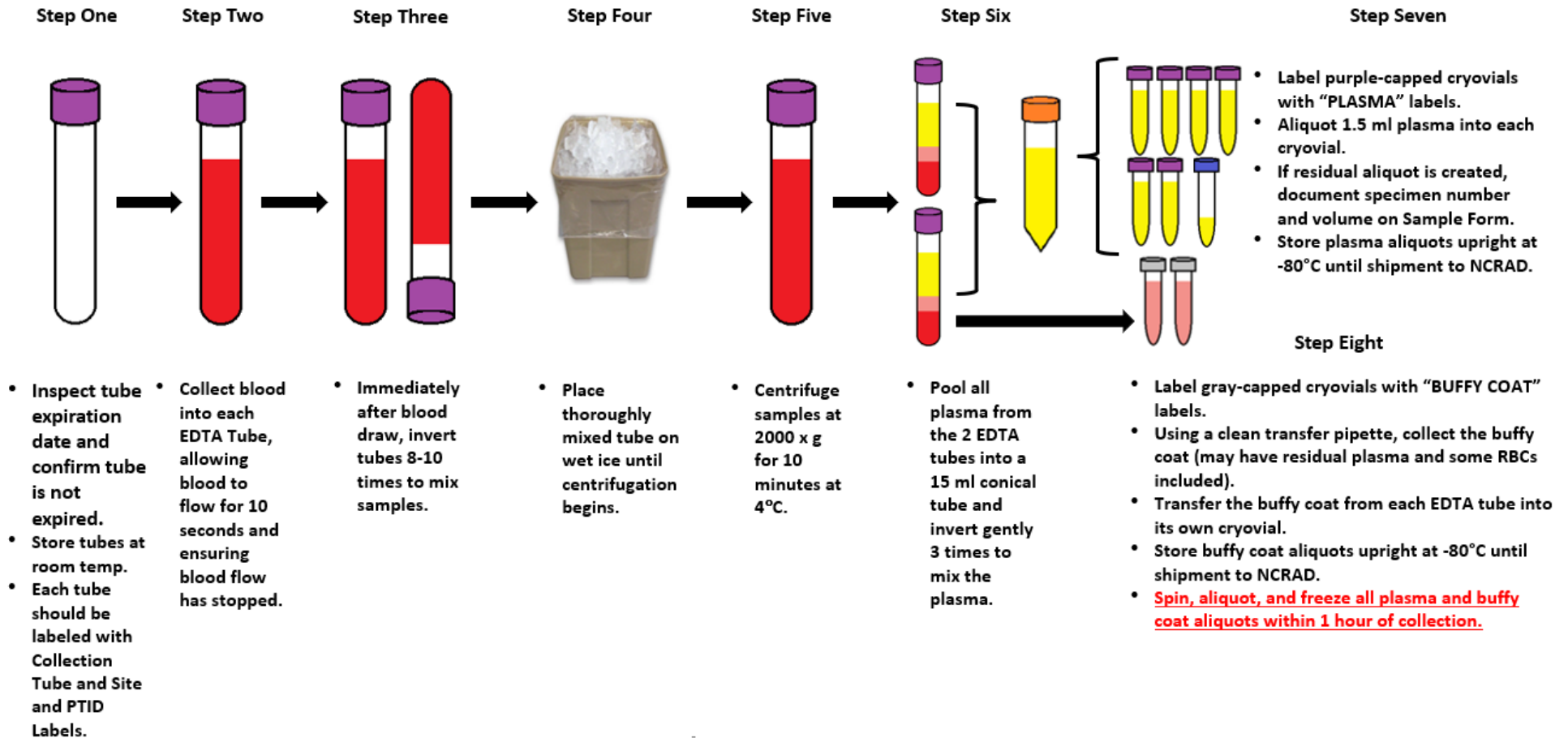

## 7.0 Incomplete or Difficult Blood Draws

**\*\*\*Important Note\*\*\***

**If challenges arise during the blood draw process, it is advised that the phlebotomist discontinue the draw. Attempt to process and submit any blood-based specimens that have already been collected to NCRAD.**

Situations may arise that prevent study coordinators from obtaining the total amount scheduled for biofluids. In these situations, please follow the below steps:

1. If the biofluids at a scheduled visit **are partially** collected:
  - a. Attempt to process and submit any samples that were able to be collected during the visit.
  - b. Document difficulties on the ‘Biological Sample and Shipment Notification Form’ prior to submission to NCRAD.
    - i. Indicate blood draw difficulties at the bottom of the ‘Biological Sample and Shipment Notification Form’ within the “Notes” section.
    - ii. Complete the ‘Biological Sample and Shipment Notification Form’ with tube volume approximations and number of aliquots created.
  - c. Contact a NCRAD coordinator and alert them of the challenging blood draw.

Draw Tube Order	Sample Type	Tube Type	Tubes to NCRAD	Ship
1	Urine	URINE: 2.0 ml cryovials with yellow cap	3	Frozen
2	Whole blood for isolation for serum	SERUM: 2.0 ml cryovials with red cap (residual volume placed in 2.0 ml cryovial with blue cap)	Up to 4	Frozen
3	Whole blood for isolation of plasma & buffy coat (for DNA extraction)	PLASMA: 2.0 ml cryovials with purple cap (residual volume placed in 2.0 ml cryovial with blue cap)	Up to 7	Frozen

		BUFFY COAT: 2.0 ml cryovial	2	Frozen
		Plasma: 2.0 ml cryovial (site stored aliquot) (24M visit ONLY)	1 (site stored)	Frozen

## 8.0 Packaging and Shipping Instructions

**ALL** study personnel responsible for shipping should be certified in biofluid shipping (i.e. IATA certification). If not available at your institution, please contact NCRAD with questions and information regarding resources.

### 8.1 Ambient Packaging and Shipping Instructions

**AMBIENT SAMPLES MUST BE SHIPPED MONDAY-THURSDAY ONLY!**

Ambient stool sample shipments should be considered as Category B UN3373 and as such must be compliant with the IATA Packing Instructions 650. Due to the level of reagent in the stool collection tubes an Excepted Quantity label provided. See the Latest Edition of the IATA Regulations for complete documentation.

Triple packaging consists of a primary receptacle(s), a secondary packaging, and a rigid outer packaging. The primary receptacles must be packed in secondary packaging in such a way that,

#### \*\*\* Ambient Shipping Packing and Labeling Guidelines \*\*\*

- The primary receptacle (Stool collection kit) must be leak proof and must not contain more than 10 ml total.
- The secondary packaging (small biohazard bag) must be leak proof.
- Absorbent material will be placed in the secondary receptacle (small biohazard bag). The absorbent material should be of sufficient quantity in order to absorb the entire contents of the specimens being shipped.
- A shipping manifest of specimens being shipped must be included between the secondary and outer packaging.
- The outer shipping container will pre-display the following labels:
  - ✓ Sender's name and address (pre-populated on UPS shipping label)
  - ✓ Recipient's name and address (pre-populated on UPS shipping label)
  - ✓ Responsible Person (pre-populated on UPS shipping label)
  - ✓ The words "Biological Substance, Category B"

under normal conditions of transport, they cannot break, be punctured or leak their contents into the secondary packaging. Secondary packaging must be secured in outer packaging with suitable cushioning material. Any leakage of the contents must not compromise the integrity of the cushioning material or of the outer packaging.

8.1.1 NCRAD Packaging Instructions—Stool Ambient Shipments

**\*\*Site Personnel instructions:**

1. Notify NCRAD of shipment by emailing NCRAD coordinators at: [alzstudy@iu.edu](mailto:alzstudy@iu.edu)
  - a. Complete and attach the Stool Sample and Shipment Notification Form to the email. (See [Appendix D](#))
  - b. Complete the participant’s gender, YOB, and Patient ID information and place the kit number label on a copy of the Stool Sample and Shipment Notification Form and provide the copy to the participant to accurately record time and date later. (See [Appendix D](#))
  - c. Apply the required labels to the ambient shipping box.
    - i. Apply the Biological Substance Category B UN3373 sticker to side of the box.

**Remember to complete the Stool Sample and Shipment Notification Form [Appendix D](#)- include a copy in your shipment.**

Top of the box



Side of the



- d. Apply the NCRAD USPS shipping label to the bottom of the ambient shipper prior to giving to the participant. **Please record the tracking number on the Stool Shipment and Notification form.**



**\*\*Participant At-Home Instructions**

2. After successfully collecting the stool samples please instruct the participant to **accurately** record the date and time the stool samples were collected on the Stool Sample and Shipment Notification Form. (See [Appendix D](#))
3. Once the Stool Sample and Shipment Notification Form has been accurately recorded, instruct the participant to place the two stool collection tubes within the provided biohazard bag with absorbent sheet.

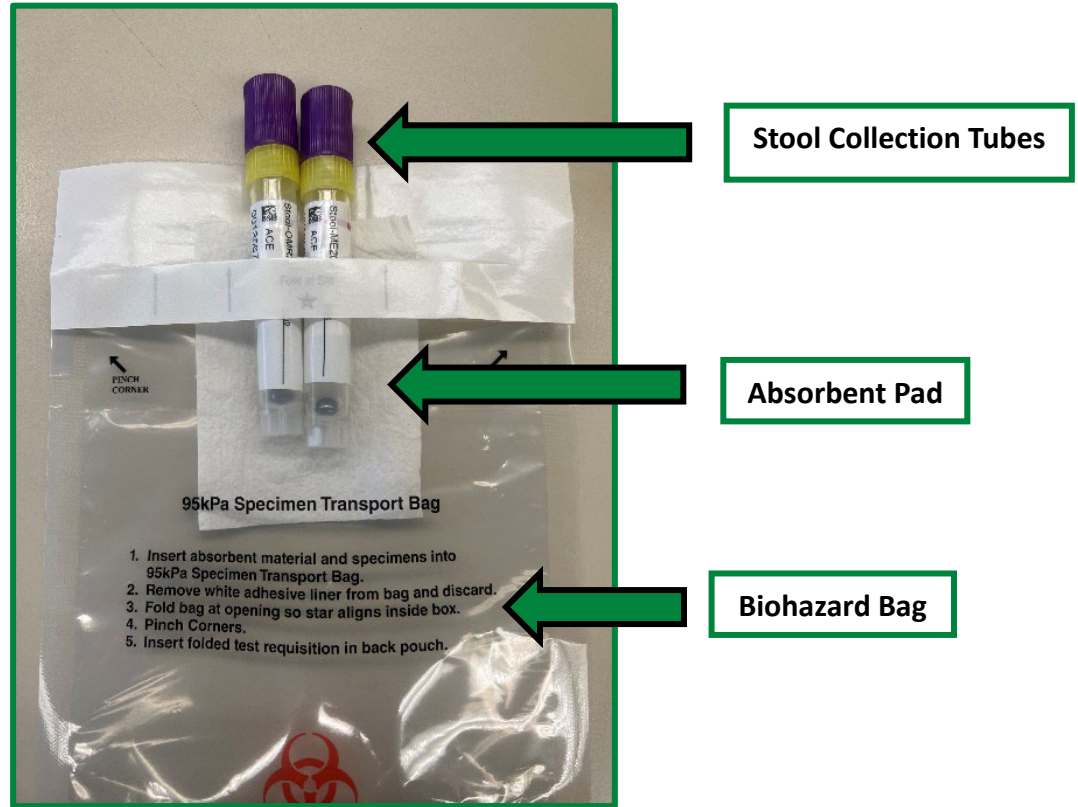

4. Instruct the participant to remove as much air as possible from the plastic biohazard bag and seal the bag according to the directions printed on the bag.
5. Next please instruct the participant to place the biohazard bag containing the stool collection tubes, in the provided ambient shipping box (IATA regulated Category B label should be applied by site personnel).
6. After the biohazard bag has been securely sealed and placed inside the ambient shipping box's Styrofoam container (cold pack included), please instruct the participant to place the Styrofoam box-top on top of the Styrofoam container containing to secure the samples. Lastly, instruct the participant to fold and place the Stool Sample and Shipment Notification Form ([Appendix D](#)) on top of the secured Styrofoam container containing the stool collection tubes, fold the box tops and apply the Uline tape strip to seal the ambient shipper.

7. Instruct the participant to please place the ambient shipping box in the designated area their daily mail is picked up to ensure that the package is picked up and received by NCRAD.



## 8.2 Frozen Packaging Information

The most important issue for shipping is to maintain the temperature of the samples. The frozen samples must never thaw; not even the outside of the tubes should be allowed to defrost. This is best accomplished by making sure the Styrofoam container is filled completely with pelleted dry ice.

**IMPORTANT!**

**FROZEN SAMPLES MUST BE SHIPPED**

**MONDAY-WEDNESDAY ONLY!**

Specimens being shipped to NCRAD should be considered as Category B UN3373 specimens and as such must be tripled packaged and compliant with IATA Packing Instructions 650. *See the Latest Edition of the IATA Regulations for complete documentation.*

**\*\*\* Packing and Labeling Guidelines \*\*\***

- The primary receptacle (frozen cryovials) must be leak proof and must not contain more than 1L total.
- The secondary packaging (biohazard bag) must be leak proof and if multiple blood tubes are placed in a single secondary packaging, they must be either individually wrapped or separated to prevent direct contact with adjacent blood tubes.
- Absorbent material must be placed between the primary receptacle and the secondary packaging. The absorbent material should be of sufficient quantity in order to absorb the entire contents of the specimens being shipped. Examples of absorbent material are paper towels, absorbent pads, cotton balls, or cellulose wadding.
- A shipping manifest of specimens being shipped must be included between the secondary and outer packaging.
- The outer shipping container must display the following labels:
  - ✓ Sender’s name and address
  - ✓ Recipient’s name and address
  - ✓ Responsible Person
  - ✓ The words “Biological Substance, Category B”
  - ✓ UN3373
  - ✓ UPS Dry Ice label and net weight of dry ice contained



Triple packaging consists of a primary receptacle(s), a secondary packaging, and a rigid outer packaging. The primary receptacles must be packed in secondary packaging in such a way that, under normal conditions of transport, they cannot break, be punctured, or leak their contents into the secondary packaging. Secondary packaging must be secured in outer packaging with suitable cushioning material. Any leakage of the contents must not compromise the integrity of the cushioning material or of the outer packaging.

8.2.1 *Frozen Packaging Instructions*

8.2.2 Notify NCRAD **IN ADVANCE** of shipment by submitting the [NCRAD Specimen Shipment Notification Form](#) online. An email will automatically be sent to [alzstudy@iu.edu](mailto:alzstudy@iu.edu) once the form is submitted.

8.2.2.1 You must complete the following fields:

- Study - ACE
- Name of study contact completing this form

- Email of study contact completing this form
- Any additional email addresses that should be notified about the status of this shipment
- Courier – *UPS*
- Shipment tracking number
- Frozen or Ambient – *Frozen*
- Sample type(s) included in shipment – *Blood*
- List each kit number that is included in this shipment
- List each participants’ ID that is included in this shipment
- Upload PDF of [NCRAD Specimen Shipment Notification Forms](#) (Appendix B) submitted online.
- Shipment Date

8.2.2.2. If email is unavailable, please call NCRAD (800-526-2839) and do not ship until you have contacted and notified NCRAD coordinators about the shipment in advance.

1. Place all frozen labeled aliquots of plasma and buffy coat aliquots from the same participant in the cryovial cryobox.
  - i. Each 25-slot cryobox will hold approximately 13 cryovial samples. Place serum, plasma, buffy coat and urine within one cryobox (4 serum, 7 plasma, 2 buffy coat, 3 urine) per participant blood draw (see below). Please do not INCLUDE the site stored GREEN cap cryovial in the cryobox.



**One cryobox containing serum, plasma, residuals, buffy coat, and urine aliquots.**

- ii. Cryoboxes should contain all of the specimens from the same patient, per time point.

- iii. **Batch shipping should be performed every (3) three months or when specimens from 5 participants accumulates, whichever is sooner.**
- 2. Label the outside of the cryoboxes with the appropriate kit number label(s). Place serum, plasma, buffy, and urine aliquots within one cryobox and place within a biohazard bag. The biohazard bags are large enough to contain one cryobox from one participant’s visit.
- 3. Place the cardboard cryobox in the clear plastic biohazard bag (do NOT remove the absorbent material found in the bag). Seal biohazard bag according to the instructions on the bag.

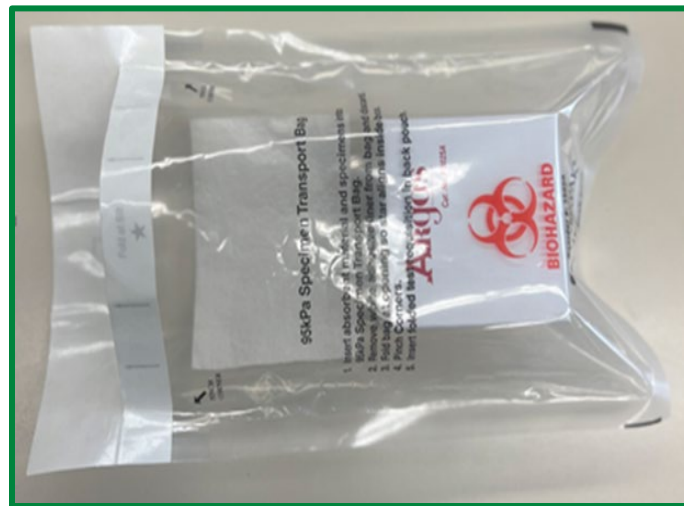

Place kit number label(s) on cryobox

- 4. Place approximately 2-3 inches of dry ice in the bottom of the Styrofoam shipping container.
- 5. Place the biohazard bag into the provided Styrofoam-lined shipping container on top of the dry ice. Please ensure that cryoboxes are placed so the cryovials are upright in the shipping container (as pictured below).
- 6. Fully cover the cryoboxes and urine collection tube with approximately 2 inches of dry ice.

7. The inner Styrofoam shipping container must contain approximately 45 lbs (or 21kg) of dry ice. The dry ice should entirely fill the inner box to ensure the frozen state of the specimens.

Full Shipping Container with  
Batched Samples and Dry Ice



8. Replace the lid on the Styrofoam carton. Place the completed Blood Sample and Shipment Notification Form and Urine Sample and Shipment Notification Form in the package on top of the Styrofoam lid for each patient specimen, and close and seal the outer cardboard shipping carton with packing tape.
9. Complete the UPS Dry Ice Label.
  - a. Net weight of dry ice in kg (must match amount on the airbill)
  - b. Do not cover any part of this label with other stickers, including pre-printed address labels.
10. Apply all provided warning labels and the pre-printed UPS return airbill to the outside of package, taking care not to overlap labels.

**IMPORTANT!**

**Complete the UPS Dry Ice label or UPS may reject or return your package.**

11. Hold packaged samples in -80°C freezer until time of UPS pick-up/drop-off.
12. Specimens should be sent to the following address via **UPS Next Day Air**. Frozen shipments should be sent **Monday through Wednesday** to avoid shipping delays on Thursday or Friday. UPS does not replenish dry ice if shipments are delayed or held over during the weekend.

ACE at NCRAD  
Indiana University School of Medicine  
351 West 10th Street  
TK-217  
Indianapolis, IN 46202  
Phone: 1-800-526-2839

13. Use UPS tracking to ensure the delivery occurs as scheduled and is received by NCRAD. Please notify NCRAD by email ([alzstudy@iu.edu](mailto:alzstudy@iu.edu)) that a shipment has been sent and include the UPS tracking number in your email.

**\*\*\*Important Note\*\*\***

**For frozen shipments, include no more than five cryovial boxes and five urine tubes (separated by patient within 5 biohazard bags) per shipping container in order to have room for a sufficient amount of dry ice to keep samples frozen up to 24 hours.**

**The labeled, processed, aliquoted, and frozen cryovials of serum, plasma and buffy coat will be shipped to NCRAD as outlined above.**

**SHIP ALL FROZEN SAMPLES MONDAY - WEDNESDAY ONLY!  
BE AWARE OF HOLIDAYS!!  
BE AWARE OF INCLEMENT WEATHER THAT MAY DELAY SHIPMENT/DELIVERY OF  
SAMPLES**

**Remember to complete the Blood Sample and Shipment Notification Form and Urine Sample and Shipment Notification Form, [Appendix B](#) and [Appendix C](#)- include a copy in your shipment AND notify the NCRAD Study Coordinator by email at [alzstudy@iu.edu](mailto:alzstudy@iu.edu) (include UPS tracking number in email) IN ADVANCE to**

### 8.3 Frozen Shipping Instructions

1. Log into the ShipExec Thin Client at kits.iu.edu/UPS.
  - a. If a new user or contact needs access, please reach out to your study contact for access.
2. Click “Shipping” at the top of the page and select “Shipping and Rating”

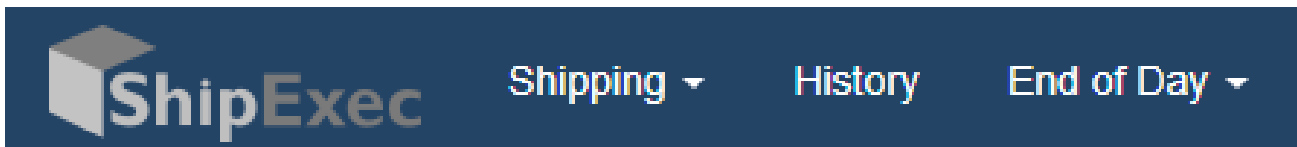

3. Select your study from the “Study Group” drop down on the right side of the main screen. Choosing your study will automatically filter the address book to only addresses within your study.

#### Ship From

Company	
Contact	
Address 1	
Address 2	
Address 3	
City	
State/Province	
Postal Code	
Country/Territory	▼
Phone	

4. Click on the magnifying glass icon in the “Ship From” section to search for your shipping address.
  - a. Search by Company (site), Contact (name), or Address 1 (first line of your site’s street address). Click Search.

- b. Click Select to the left of the correct contact information.
5. Verify that both the shipping information AND study reference are correct for this shipment.
  - a. If wrong study contact or study reference, click Reset in the bottom right of the screen to research for the correct information.
6. Enter Package Information
  - a. Frozen shipments
    - i. Enter the total weight of your package in the “Weight” field.
    - ii. Enter the dry ice weight in the “Dry Ice Weight” field.
    - iii. If the “Dry Ice Weight” field is higher than the “Weight” field, you will receive an error message after clicking “Ship” and need to reenter these values.
  - b. Click Ship in the bottom right of the page when complete.
7. If your site does not already have a daily UPS pickup, you will need to schedule one
  - a. Click the blue Pickup Request button. Enter the earliest pickup time and latest pickup time in 24-hr format.
  - b. Give a name & phone number of someone who the UPS driver can call if having issues finding the package.
  - c. Give the Floor and Room Number (if needed) to be as descriptive as possible where this package needs to be picked up from. Click Save.
8. Print the airbill that is automatically downloaded.
  - a. To reprint airbill, click History at the top left of the page.
  - b. Click Detailed Report from the dropdown menu on the right side of the page.
  - c. Enter tracking number if known. Otherwise, search by ship date. Click Search.
  - d. Click print icon on right side of the tracking number line.
9. Fold airbill and place inside plastic UPS sleeve.
10. Peel the back off of the UPS sleeve, and stick the sleeve to the package.
11. A UPS Pickup is automatically scheduled at the address you are shipping from, and the pickup is charged to NCRAD.

- a. If shipment occurs too late in the day for an automatic UPS pickup, you will receive an email stating that the pickup could not be scheduled, and you will need to make other arrangements.

## 9.0 Data Queries and Sample Reconciliation

[Specimen Collection and Processing Forms](#) must be completed on the day that samples are collected since they capture information related to the details of the sample collection and processing. These forms include information that will be used to reconcile sample collection and receipt, as well as information essential to future analyses.

NCRAD will collaborate with the data team to reconcile information captured in the database compared to samples received and logged at NCRAD. Additional discrepancies may be sent directly to the Center staff to reconcile.

**Effective 3/1/2026, the following digital forms must be used for all submissions:**

- [ACE Specimen Collection and Processing Forms](#)
  - Submit online → download and print the PDF → include the physical copy in the batch shipment and attach the PDF in the [Shipping Form](#).

Thank you for completing the sample collection and shipping information for participant IN1234 (Kit 111112).

You will receive a copy of the completed form in your email. You may also download a copy of the completed form by clicking the "Download" button below.

Please remember to include a hard copy of the **condensed** (1 page) Sample Collection & Processing Form in your shipment.

To generate an air waybill and schedule a UPS pickup, please go to the [NCRAD UPS Portal](#).

Prior to shipping samples to NCRAD, please remember to complete the [Shipment Notification Survey](#).

Thank you!

Download your survey response (PDF): [Download](#)

[Close survey](#)

- This form replaces the previous ACE Sample Forms.
  - Note: If you are unable to access the online submission form during the visit, you may print and complete the old form in the

interim. Please ensure the online form is completed as soon as computer access is available.

- These forms are designed to improve efficiency, enhance tracking, and reduce errors with built-in validation checks.

Data queries or discrepancies with samples shipped and received at NCRAD may result from:

- Missing samples
- Incorrect samples collected and shipped
- Damaged or incorrectly prepared samples
- Unlabeled samples, samples labeled with incomplete information, or mislabeled samples
- Discrepant information documented on the Sample and Shipment Notification Forms and logged at NCRAD compared to information entered into the study database.
- Samples that are frozen and stored longer than one quarter at the site
- Use of an incorrect Sample and Shipment Notification Forms

## 10.0 Appendices List

[Appendix A: Rate of Centrifugation Worksheet](#)

[Appendix B: Blood Sample and Shipment Notification Form](#)

[Appendix C: Urine Sample and Shipment Notification Form](#)

[Appendix D: Stool Sample and Shipment Notification Form](#)

## Appendix A: Rate of Centrifuge Worksheet

Please complete and return this form by email to the NCRAD Study Team if you have any questions regarding sample processing. The correct RPM will be sent back to you.

### Submitter Information

**Name:**

**Site:**

**Submitter e-mail:**

### Centrifuge Information

Please answer the following questions about your centrifuge.

#### Centrifuge Type

Fixed Angle Rotor:       Swing Bucket Rotor:

#### Radius of Rotation (mm):

Determine the centrifuge's radius of rotation (in mm) by measuring distance from the center of the centrifuge spindle to the bottom of the device when inserted into the rotor (if measuring a swing bucket rotor, measure to the middle of the bucket).

#### Calculating RPM from G-Force:

$$RCF = \left( \frac{RPM}{1,000} \right)^2 \times r \times 1.118 \quad \Rightarrow \quad RPM = \sqrt{\frac{RCF}{r \times 1.118}} \times 1,000$$

RCF = Relative Centrifugal Force (G-Force)

RPM = Rotational Speed (revolutions per minute)

R= Centrifugal radius in mm = distance from the center of the turning axis to the bottom of centrifuge

Comments:

**Please send this form to NCRAD Study Coordinator at [alzstudy@iu.edu](mailto:alzstudy@iu.edu)**

## Appendix B: Blood Sample and Shipment Notification Form

National Centralized Repository for  
Alzheimer's Disease and Related Dementias

### ACE Specimen And Processing Form

Please complete the Specimen Collection and Processing Form below:

NCRAD Email: [alzstudy@iu.edu](mailto:alzstudy@iu.edu) | NCRAD Phone: 1-800-526-2839  
NCRAD ACE Study Coordinator: [dikeys@iu.edu](mailto:dikeys@iu.edu) | Phone: 317-274-7890

---

**Site Information**

**Study Site**

**Name of Contact at Site**

**Email Address of Staff Member Completing this Form**   
A copy of the completed sample form and/or shipping manifests will be sent to this address.

---

**Participant Information**

ACE Patient ID Required Format:  
Format: LL####  
L = Letter  
# = Digit

Alpha Component	Numerical Component
Emory University: EM University of Pittsburgh: PI Wake Forest University: WF	####

Please exclude dashes

**ACE Patient ID Number** Your site:  Alzheimer's Consortium

The PTID entered: \_\_\_\_\_ does not match the required format. Please review this response.

**Participant Biological Sex**

**Participant Year of Birth**  Alzheimer's Consortium

---

**Visit Information**

**Biological Sample Collected**

**Kit Number**

**Date & Time of Sample Collection**  Placeholder: X3 Frost Freezer Network

**Date & Time Participant Last Ase**  Placeholder: X3 Frost Freezer Network

---

**Visit Notes**

**Visit Notes**

Condensed Form to Include in Shipment



### ACE Sample and Processing Form

Page 1

#### ACE Sample and Processing Form

NCRAD Email: [alzstudy@iu.edu](mailto:alzstudy@iu.edu) | NCRAD Phone: 1-800-526-2839

NCRAD ACE Study Coordinator: [dikeys@iu.edu](mailto:dikeys@iu.edu) | Phone: 317-274-7890

**NOTE:**

If you are unable to access the online submission form, you can print and fill out the old form during the visit. You can then fill out the online form when you have access to a computer.

To: Diont'e Keys Email: [alzstudy@iu.edu](mailto:alzstudy@iu.edu) Phone: 1-800-526-2839

**General Information:**

UPS tracking #: \_\_\_\_\_

From: \_\_\_\_\_

Date: \_\_\_\_\_

Phone: \_\_\_\_\_

Email: \_\_\_\_\_

Study: ACE Visit: BL M12 M24

Site ID: \_\_\_\_\_ ACE Patient ID #: \_\_\_\_\_

Sex: M F Year of Birth: \_\_\_\_\_



**Blood Collection:**

Date Drawn: [MM/DD/YY]	Time of Draw: [HHMM]
Date participant last ate: [MM/DD/YY]	Time participant last ate: [HHMM]

**Blood Processing:**

Serum (Red-top) Tube (10 mL)		Plasma & Buffy Coat (Purple-top) Tube (10 mL)	
Time spin started:	_____ [HHMM]	Time spin started:	_____ [HHMM]
Duration of centrifuge:	_____ Minutes	Duration of centrifuge:	_____ Minutes
Temp of Centrifuge:	_____ °C	Temp of Centrifuge:	_____ °C
Rate of centrifuge:	_____ x g	Rate of centrifuge:	_____ x g
Original volume drawn (1 x 10 mL tube):	_____ mL	Original volume of EDTA #1:	_____ mL
		Original volume of EDTA #2:	_____ mL
Time aliquoted:	_____ [HHMM]	EDTA #1 specimen number (Last 4 digits):	_____
Number of 1.5 mL serum aliquots created (red cap):	_____	EDTA #2 specimen number (Last 4 digits):	_____
If applicable, volume of residual serum aliquot (<1.5 mL in blue cap):	_____ mL	Time aliquoted:	_____ [HHMM]
If applicable, last four digits of residual serum aliquot:	_____	Number of 1.5 mL plasma aliquots created (purple cap):	_____
Time aliquots placed in freezer:	_____ [HHMM]	If applicable, volume of residual plasma aliquot (<1.5 mL in blue cap):	_____ mL
Storage temperature in freezer:	_____ °C	If applicable, last four digits of residual plasma aliquot:	_____
		Record last four digits of site stored plasma aliquot (green cap):	_____ mL
		Time aliquots placed in freezer:	_____ [HHMM]
		Storage temperature in freezer:	_____ °C
		Buffy coat #1 volume (clear cap, one per 10 mL EDTA tube)	_____ mL
		Buffy coat #2 volume (clear cap, one per 10 mL EDTA tube)	_____ mL

Notes:

## Appendix C: Urine Sample and Shipment Notification Form

National Centralized Repository for  
Alzheimer's Disease and Related Dementias

### ACE Specimen And Processing Form

Please complete the Specimen Collection and Processing Form below.

NCRAD Email: [alzstudy@iu.edu](mailto:alzstudy@iu.edu) | NCRAD Phone: 1-800-526-2839  
NCRAD ACE Study Coordinator: [dikeys@iu.edu](mailto:dikeys@iu.edu) | Phone: 317-274-7890

Site Information

Study Site:

Name of Contact at Site:

Email Address of Staff Member Completing this Form:

Participant Information

ACE Patient ID Required Format:  
Format: LL####  
L = Letter  
# = Digit

Alpha Component	Numerical Component
Emory University: EM	
University of Pittsburgh: PI	####
Wake Forest University: WF	

Please exclude dashes

ACE Patient ID Number:

Your site:

The PTID entered: \_\_\_\_ does not match the required format. Please review this response.

Participant Biological Sex:

Participant Year of Birth:

Visit Information

Biological Sample Collected:

Kit Number:

Date & Time of Sample Collection:

Date & Time Participant Last Ate:

Visit Notes

Visit Notes:

Condensed Form to Include in Shipment



### ACE Sample and Processing Form

Page 1

ACE Sample and Processing Form  
NCRAD Email: [alzstudy@iu.edu](mailto:alzstudy@iu.edu) | NCRAD Phone: 1-800-526-2839  
NCRAD ACE Study Coordinator: [dikeys@iu.edu](mailto:dikeys@iu.edu) | Phone: 317-274-7890

Response was added on 02/09/2026 2:38pm.

REDCap Record ID: 5  
Survey Responder Information Site 003 - Wake Forest University  
Name of Contact at Site Kelley Faber  
Email Address kelfaber@iu.edu

Participant Information Participant ID IN1234  
Sex Female  
Year of Birth 1900

Urine Processing Summary

Visit Information Sample Type Urine  
Visit Baseline  
Kit Number 111111  
Collection Information Sample Collection Date and Time 02-06-2026 10:03  
Date and Time Participant Last Ate 02-06-2026 08:03  
Number of 1.5 mL Urine Aliquots Created 3  
Processing Information Time Aliquots Placed in Freezer 09:37  
Storage Temperature in Freezer -80 °C

**NOTE:**

**If you are unable to access the online submission form, you can print and fill out the old form during the visit. You can then fill out the online form when you have access to a computer.**

To: Diont'e Keys Email: [alzstudy@iu.edu](mailto:alzstudy@iu.edu) Phone: 1-800-526-2839

*General Information:*

**UPS tracking #:** \_\_\_\_\_

From: \_\_\_\_\_ Date: \_\_\_\_\_

Phone: \_\_\_\_\_ Email: \_\_\_\_\_

**Study:** ACE

**Visit:** Pre-intervention

**Site ID:** \_\_\_\_\_ **ACE Patient ID #:** \_\_\_\_\_

**Sex:** M F **Year of Birth:** \_\_\_\_\_



*Urine Collection:*

Date Collected:	[MM/DD/YY]	Time of Collection:	[HHMM]
Date participant last ate:	[MM/DD/YY]	Time participant last ate:	[HHMM]

*Urine Processing:*

<b>Sterile screw-cap urine collection cup with integrated transfer device and C&amp;S preservative tube, 4ml</b>	
Number of 1.5 mL urine aliquots created (yellow cap):	_____
Time aliquots placed in freezer:	_____ [HHMM]
Storage temperature in freezer:	_____ °C

*Notes:*

### Appendix D: Stool Sample and Shipment Notification Form

*Please email the form on or prior to the date of shipment.*

To: Diont'e Keys Email: [alzstudy@iu.edu](mailto:alzstudy@iu.edu) Phone: 1-800-526-2839

**FOR STUDY STAFF TO COMPLETE:**

Tracking number: \_\_\_\_\_

(Located right below the barcode of the USPS label)

From: \_\_\_\_\_ Date: \_\_\_\_\_

Phone: \_\_\_\_\_ Email: \_\_\_\_\_

**FOR STUDY STAFF TO COMPLETE:**

**Study:** ACE      **Visit:** BL M12 M24

**Site ID:** \_\_\_\_\_ **ACE Patient ID #:** \_\_\_\_\_

**Sex:** M F      **Year of Birth:** \_\_\_\_\_

KIT BARCODE

**FOR STUDY PARTICIPANT TO COMPLETE:**

*Stool Collection:*

Date Collected: [MM/DD/YY]	Time of Collection: (24-hour clock)
Date last ate: [MM/DD/YY]	Time last ate: (24-hour clock)